

# K

# RENAULT TRUCKS K



[renault-trucks.com](http://renault-trucks.com)



# 100 % FULLY CONNECTED TRUCKS

INCLUDING 1 YEAR OF OPTIFLEET SERVICES



## PLANNED MAINTENANCE IN LINE WITH MY ACTUAL USE



### CONNECTED PERSONNALISED MAINTENANCE SCHEDULE

Connectivity enables your approved Renault Trucks Dealer to work on a tailor-made maintenance plan for your vehicle and its actual needs to provide the right maintenance operations at the best time. A respected maintenance plan providing rationalised workshop visits and maximum vehicle availability.

## OPTIMISED REMOTE FLEET MANAGEMENT IN REALTIME



### OPTIFLEET HELPS ME MAKE THE MOST OF MY VEHICLES

A fleet management solution that improves your ongoing operations by accessing your vehicle data wherever, whenever and however you need it.

**FULLY COMPREHENSIVE SUBSCRIPTION:**  
unlimited data sharing, roaming included.  
Access to the web portal, the mobile application and API, for an unlimited number of users.

# ...WITH OUR EXPERTISE TO GET THE BEST OUT OF YOUR FLEET

## LOCATE YOUR VEHICLES IN REAL TIME



### WITH THE OPTIFLEET MAP MODULE

- Prepare journeys in line with customer POIs and truck restrictions
- Real-time operations monitoring: fuel levels, geo-barrier alerts, time, etc.
- Analysis of routes

## COACHING DRIVERS REMOTELY



### WITH THE OPTIFLEET CHECK MODULE

- The Eco-score performance report
- Analysis of driving style
- Fuel theft alerts
- Customisable analysis reports

## TRAINING IN RATIONAL DRIVING



### WITH OPTIFUEL TRAINING

#### 3 TRAINING OBJECTIVES:

- Fuel saving
- Greater safety awareness and implementation (reducing accidents and therefore increasing productivity)
- Rational driving to reduce maintenance (anticipation, average speed, optimised braking, use of the Optidriver gearbox, etc.)

#### A FULL DAY TWO-PHASE TRAINING PROGRAMME:

- Learning technical parameters, understanding the driveline, mastering the controls, etc.
- Applying best rational driving practices in real situations



# A NETWORK ALWAYS CLOSE AT HAND

With 1,550 service points worldwide, Renault Trucks is always on hand to serve you quickly and efficiently wherever you are.



## A NETWORK OF PROFESSIONALS, FOR PROFESSIONALS

You can always count on the professionals at Renault Trucks service centres, equipped with specific and efficient equipment geared to your vehicle's technology and regularly updated in diagnostic tools.



### 2 YEAR WARRANTY

on parts for any operation carried out by an authorised Renault Trucks Dealer.



### A UNIQUE AND GENUINE OFFER

The quality of original parts: reliable, robust and approved to maintain your vehicle's performance.



### EXCHANGE OFFER

A range of refurbished parts, designed to guarantee your vehicles' performance at the best price and give them a second life.

# A CUSTOMISED MAINTENANCE OFFER

In order to optimise your vehicle's performance and cost of ownership, its maintenance is monitored and planned in line with its actual use.

## START & DRIVE MAINTENANCE CONTRACT

A range of reassuring service contracts geared to your vehicle and needs. A personalised contract for each vehicle based on the personalised maintenance schedule (PMS). Features contractually defined maintenance operations at specific intervals. Contracts available for all Renault Trucks ranges for up to 5 years.

## TOTAL FLEXIBILITY, PAY AS YOU DRIVE

Start & Drive contracts are offered with a wide choice of options on annual, monthly or distance-based terms. With the cost per kilometer basis, you only pay when you are driving. This allows you to benefit from a maintenance contract geared to your needs with total flexibility and no compromise between profitability and uptime.

REFERENCE	PERFORMANCE Standard	PERFORMANCE Maximum	EXCELLENCE
			OPTIONS
	OPTIONS	OPTIONS	WEAR PARTS
OPTIONS	REPAIRS (on the Driveline)	REPAIRS (entire vehicle)	REPAIRS (entire vehicle)
PREVENTIVE MAINTENANCE	PREVENTIVE MAINTENANCE	PREVENTIVE MAINTENANCE	PREVENTIVE MAINTENANCE



# DRIVELINE WITH 3 YEAR WARRANTY, DESIGNED FOR PROFITABILITY

Engine, gearbox, axles and on-board technologies all contribute to making your vehicle economical in use and profitable for your business.



## 1 NEW ENGINE RATING 13 L 420 HP (EURO 3)

- More powerful engine brake
- More dynamic performance
- Broader maximum torque range
- Better hill-start performance

## ENJOYING THE DRIVE IS NO LONGER A LUXURY

## 2 OPTIDRIVER AUTOMATED GEARBOX for greater driving comfort and safety.

### OPTIDRIVER XTREM

The more robust version of the Optidriver gearbox with reinforced components, suitable for extreme conditions. Standard on Euro 3 and Euro 5 models.

### OPTIDRIVER XTREM + XTENDED

Features one or two extra-slow gears to improve performance and make starting the vehicle easier when carrying heavy loads.

## 3 OPTIMISED DRIVE AXLES

- Double reduction drive axles fitted as standard and in reinforced versions for mining and logging applications.
- Large choice of rear axle ratios to face any usage conditions
- Superior reliability and long operational life for maximum rate of use

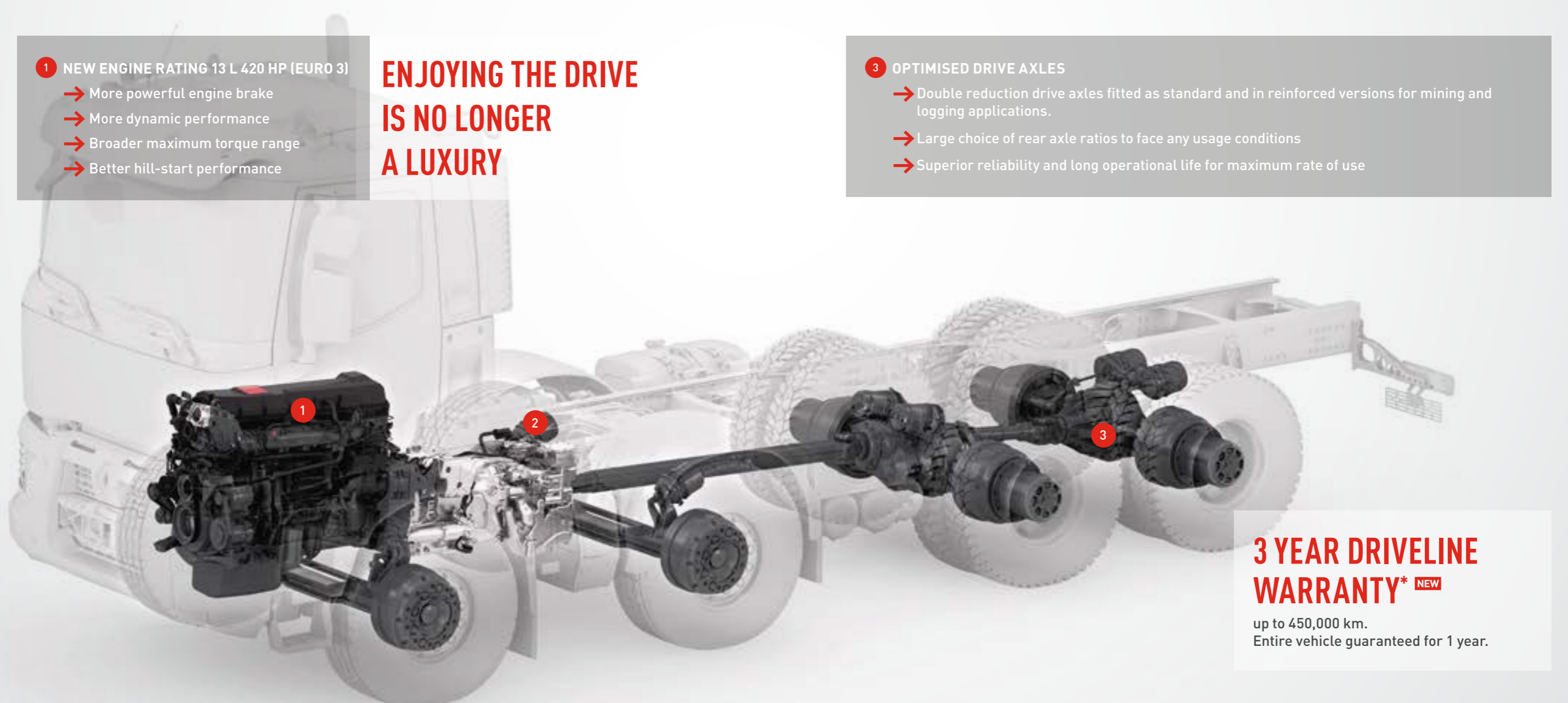

## 3 YEAR DRIVELINE WARRANTY\* NEW

up to 450,000 km.  
Entire vehicle guaranteed for 1 year.

\*applicable to selected countries complying with the Renault Trucks International guarantee

# ROBUSTNESS UNDER ALL CONDITIONS

The Renault Trucks K only uses components and solutions that are rigorously tested. Robustness that is reflected in the vehicle's exterior design.

**CYCLONIC AIR PRE-FILTER**  
designed to operate in dusty environments.

**MECHANICAL SUSPENSIONS FROM 8 TO 10 T**  
with greased joints for operating under the most extreme conditions

**8-5 MM STRAIGHT SIDE CHASSIS RAILS**  
to make body fitting easier

**SEPARATE ELECTRICAL AND PNEUMATIC BUNDLES**  
to make maintenance easier

**STEEL DIESEL TANKS**  
designed for high ground clearance.

**HEADLIGHT PROTECTION GRIDS**  
with polycarbonate optics (standard) set back from the bumper for better impact resistance.

**XTREM OPTIDRIVER**

**PROTECTIVE SCREENS**  
on devices exposed to impacts: EACU, pneumatic devices.

**3-PARTS ALL STEEL BUMPER**  
as standard, to reduce maintenance costs.

**SEMI-ELLIPTICAL OR PARABOLIC SUSPENSIONS**  
26t parabolic with 3 blades, 32t semi-elliptical with 11 blades, 38t Xtrem parabolic with 4 blades.

**EXTENDED RANGE OF REINFORCED SIDE FRAMES**  
to guarantee the frame's mechanical resistance.



# OUTSTANDING GROUND CLEARANCE CAPACITY

Chassis, driveline and cab all combined to enable you to operate in the most extreme situations with maximum mobility and efficiency. Steering precision and short turning radius deliver excellent handling.

**REDUCED TURNING RADIUS,**  
to make maneuvering easier.

**BEST APPROACH ANGLE ON  
THE MARKET: 32°**

**515 MM GROUND CLEARANCE  
UNDER THE TANK**

**412 MM GROUND CLEARANCE  
UNDER THE AXLE**

**DOUBLE REDUCTION TANDEM  
DRIVE AXLE**

for more traction on difficult terrain.

**4X4, 6X6, 8X6 AND 8X8 MODELS**  
to give the vehicle greater traction.

**PROTECTION SCREEN**  
under the radiator and air dryer.

**INTER-WHEEL AND DRIVE AXLE  
DIFFERENTIAL LOCKS**  
standard on all models.



# OUTSTANDING DRIVING COMFORT

## 1 A "PANORAMIC" DASHBOARD\* DESIGNED LIKE A COCKPIT **NEW**

- Curved dashboard design to ensure all functions are within easy reach
- Cup holder
- Phone rest with USB-C plugs

## 2 STORAGE DRAWER FOR A4 FORMAT DOCUMENTS\* **NEW**

- ## 3 START THE VEHICLE WITHOUT A KEY **NEW**
- with a start button

# THE BEST STEERING COLUMN ON THE MARKET

## 4 MULTI-DIRECTIONAL STEERING COLUMN **NEW**

- 3 adjustable and broader ranges to accurately match the most suitable driving position for your body type
- Intuitive steering wheel foot control for selecting an ideal driving position
- Easy access to the cab when the steering wheel is raised
- More knee room
- Engine vibrations absorbed for greater comfort



\*optional



# HOMELY-LIKE LIVING AREA

## 1 NEW ULTRA-COMFORTABLE LOWER BUNK "SÉRÉNITÉ" **NEW**

- Length 2018 mm
- Width 671 mm behind the seats, 791 mm in the centre
- Twice as many springs and a thicker mattress that adapt to all body types
- Mattress can be separated from the base when using fitted sheets
- New, easy to clean, textured fabric
- Memory foam mattress\* (2,000 mm x 700 mm x 30 mm), filling 300 g / m<sup>3</sup>, fabric matching the cab upholstery

## 2 CUP HOLDER within easy reach **NEW**

## 3 FRONT STORAGE BOXES within reach above the dashboard

## 4 INTERIOR / EXTERIOR STORAGE Makes loading heavy luggage easier (large space for a pack of 6 1.5L water bottles)

## 5 TWO USB-C SOCKETS accessible from the bunk **NEW**

## 6 SILENT ELECTRIC REFRIGERATOR\* 40 litre capacity

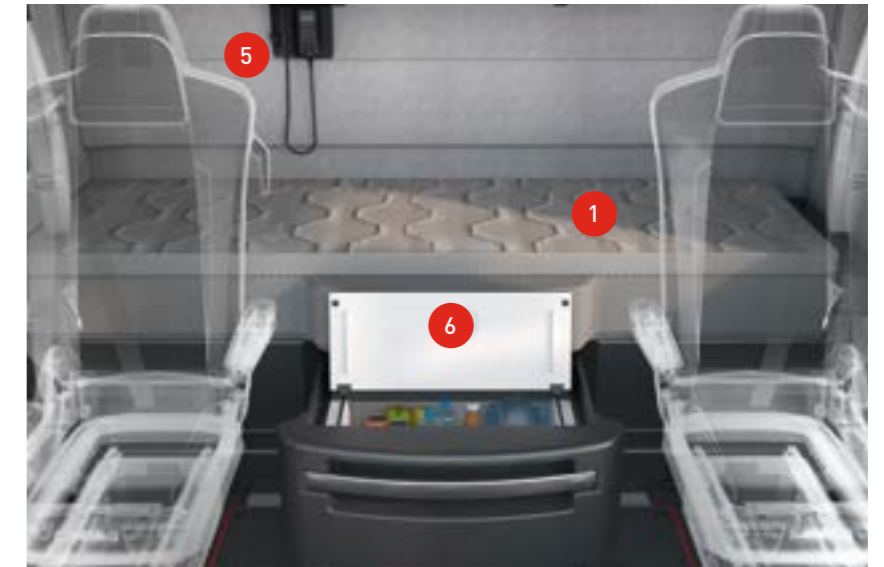

\*optional





# MAKING EVERY DAY SAFER



→ **HILL START AID (HSA)**  
Automatically manages braking when performing a hill-start, making it easier to prevent the vehicle from rolling back.



→ **YELLOW PAINTED CAB ACCESS STEPS / HANDLES\***  
Improves safety when getting off and onto the vehicle.



→ **"ANTI-RUN AWAY"**  
Automatic Park Brake activation when driver presence is not detected.



→ **UP TO FOUR CAMERAS\***  
for perfect vision. Rear and side cameras to ensure maximum safety.



→ **SAFETY SENSORS\***  
Ultrasonic presence sensors detect vulnerable road users on the side opposite the driver. The warning is given by visual (LED) and audible alarms.



→ **VISION DOOR\***  
The passenger has an additional window at the height of cyclists and pedestrians.

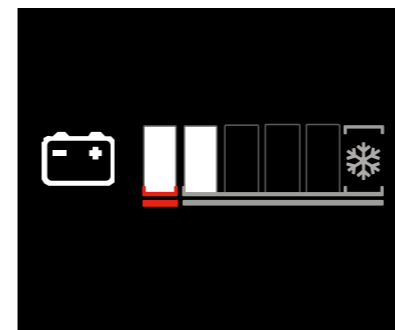

**BATTERY CHARGE INDICATOR\***

→ **EBS**  
Electronic Braking System.



**TYRE PRESSURE MONITORING SYSTEM\***  
Displays a visual alert in case of abnormal pressure.

→ **ASR**  
Anti-Spin Regulation.

→ **NEUTRAL INHIBITION**  
Prevents the driver from "going into neutral" when driving downhill.

\*optional

# DRIVELINE

## ENGINES - EURO III

DXi 11	
6 cylinders inline. 10.8L	
330 hp	1650 Nm
380 hp	1800 Nm
440 hp	2000 Nm

DXi 13	
6 cylinders inline. 12.8L	
420 hp	2040 Nm
460 hp	2200 Nm
500 hp	2400 Nm

## ENGINES - EURO V

DXi 11	
6 cylinders inline. 10.8L	
380 hp	1800 Nm
430 hp	2050 Nm
460 hp	2200 Nm

DXi 13	
6 cylinders inline. 12.8L	
440 hp	2200 Nm
480 hp	2400 Nm
520 hp	2500 Nm

## AUTOMATED GEARBOXES

OPTIDRIVER XTREM
12 reinforced gears
Max. torque 2550 Nm
12 forward + 3 reverse gears with reinforced gearbox

OPTIDRIVER XTENDED
13-14 reinforced gears
Max. torque 2550 Nm
12 forward gears + 1 or 2 additional crawler gears

## DRIVE AXLES

P1361 (double reduction)
PMR2661 (double reduction)
PMR3361 (double reduction)
PMR3361R (double reduction)

4x2 / 4x4
6x4 / 8x4 / 6x6 / 8x6 / 8x8
6x4 / 8x4 / 6x6 / 8x6 / 8x8
6x4 / 8x4 / 6x6 / 8x6 / 8x8



# CABS

## DAY CAB - NIGHT & DAY CAB - SLEEPER CAB

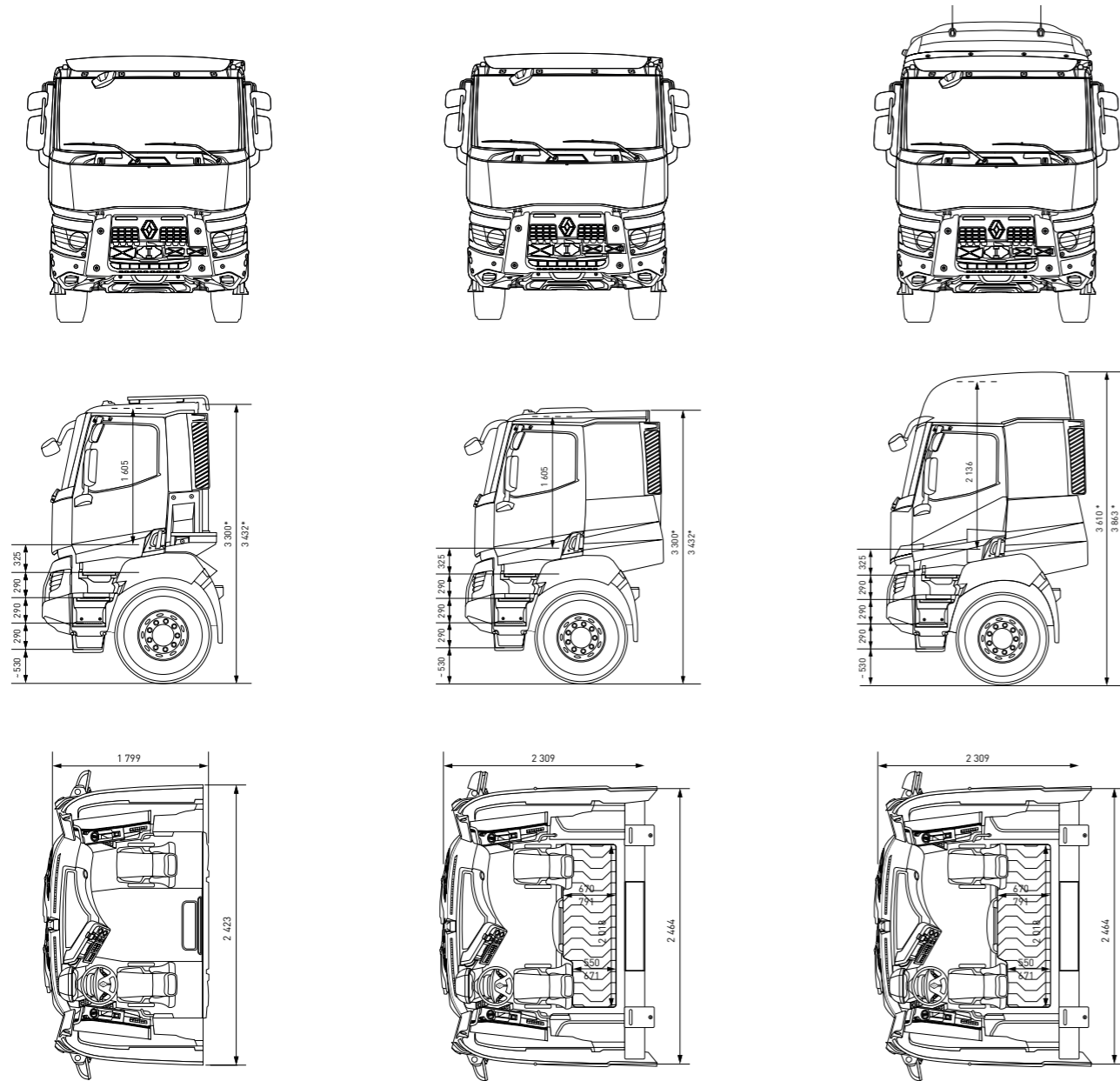

\* Loaded / empty.

		DAY CAB	NIGHT & DAY CAB	SLEEPER CAB
Type		Standard roof	Standard roof	Raised roof
Interior roof		1,605 mm	1,605 mm	2,136 mm
Height over tunnel		1,405 mm	1,405 mm	1,936 mm
Floor		200 mm engine tunnel		
Steps	4x2 - 6x4 - 8x4	3		
	4x4 - 6x6 - 8x6 - 8x8	4		

## CREW CABS

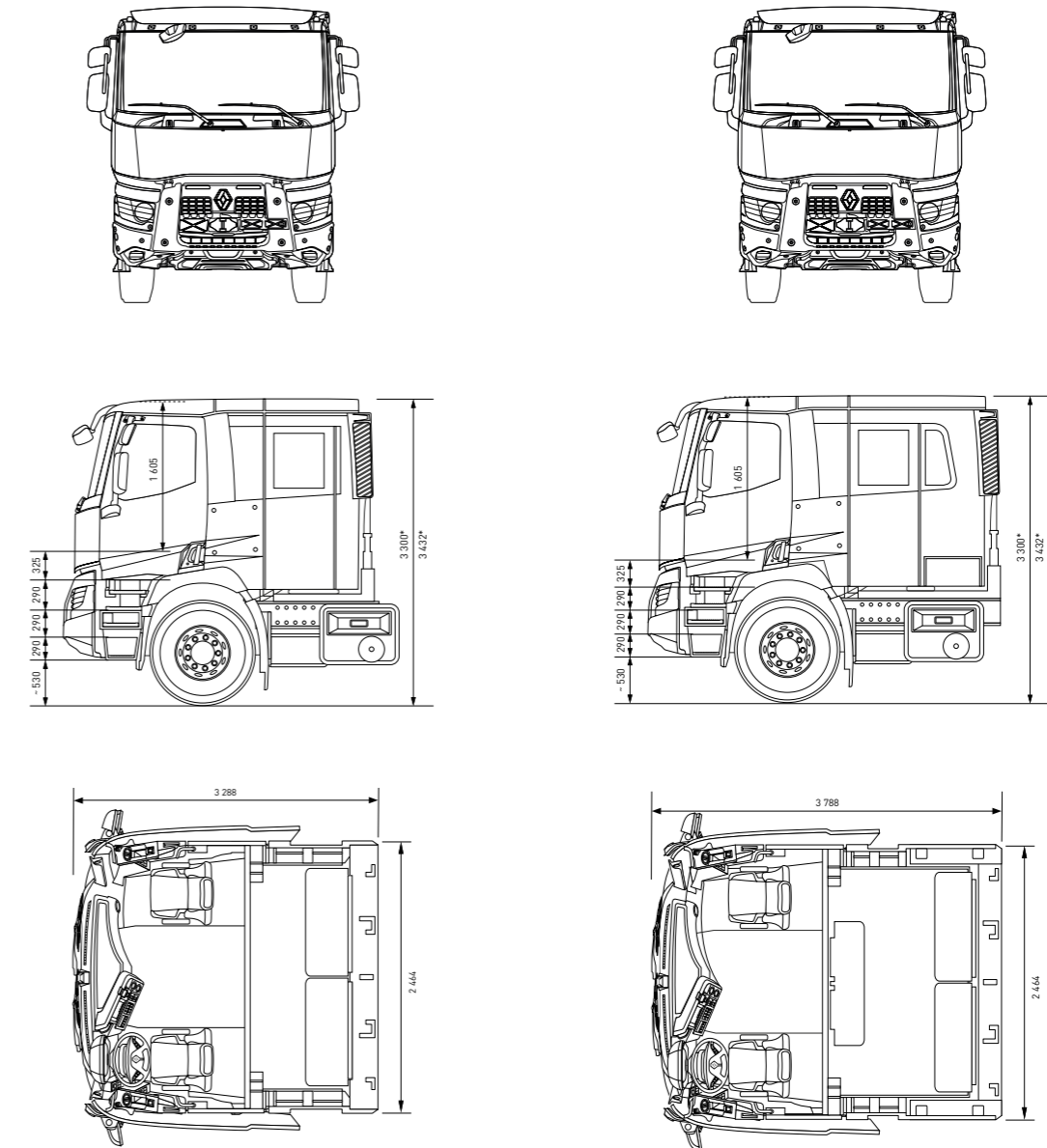

		XL CAB	XXL CAB
Type		4 door cab 6 seats	4 door cab 8 seats
Interior roof		1,605 mm	1,605 mm
Height over tunnel		1,405 mm	1,405 mm
Floor		200 mm engine tunnel	
Steps		3	
		4	

\*For all the 4x2 and 4x4 tractors.

# RANGE POSTER

## EURO III

Cabs	Type	Wheel configurations	GVW / GCW (tons)	Engines	Power (hp)	Gearbox	Chassis Rails
Day Night & Day Sleeper Crew	Rigid	4x2 4x4	18-19 / 70	DXi 11	330 380 440	Optidriver Xtrem 12 speeds	Medium Heavy Xtrem
		6x4 6x6	26 / 100 35 / 100				
		8x4 8x6	32 / 80 42 / 80 50 / 80				
		8x8*	50 / 70	DXi 13	420 460 500	Optidriver Xtended 13 where 14 speeds**	
		Tractor	4x2 4x4	19-21 / 70 19-21 / 65			
			6x4 6x6	26 / 150 35 / 100			

## EURO V







Cabs	Type	Wheel configurations	GVW / GWR (tons)	Engines	Power (hp)	Gearbox	Frame
Day Night & Day Sleeper Crew	Rigid	4x2 4x4	18-19 / 70	DXi 11	380 430 460	Optidriver Xtrem 12 speed	Medium Heavy Xtrem
		6x4 6x6	26 / 100 35 / 100				
		8x4 8x6	32 / 80 42 / 80 50 / 80				
		8x8*	50/70	DXi 13	440 480 520	Optidriver Xtended 13 or 14 speeds**	
		Tractor	4x2 4x4	19-21 / 70 19-21 / 65			
			6x4 6x6	26 / 150 35 / 100			

\*8x8 Rigid only with DXi13 engine.

\*\*Optidriver Xtended 14 speeds only available on 4x4 and 6x6.

# CHASSIS

## WHEEL CONFIGURATIONS

4x2	4x4	6x4	6x6
			
Tractor Rigid	Tractor Rigid	Tractor Rigid	Tractor Rigid
8x4	8x6	8x8	
			
Rigid Tractor (customer adaptation)	Rigid Tractor (customer adaptation)	Rigid Tractor (customer adaptation)	





We recommend Renault Trucks Oils.  
Dimensions and characteristics are only indicative.  
The manufacturer reserves the right to modify them without notice.  
Renault Trucks SAS with a capital of € 50,000,000 - 954 506 077 RCS Lyon



[renault-trucks.com](http://renault-trucks.com)

